

ijcrr

Vol 04 issue 16
Category: Review
Received on:11/06/12
Revised on:27/06/12
Accepted on:08/07/12

PERFORMANCE ANALYSIS OF DOMESTIC REFRIGERATOR USING WIRE-ON-TUBE CONDENSOR- A REVIEW

Vivek Sahu¹, Pooja Tiwari¹, Abhishek Tiwari²

¹SRIT, Jabalpur

²GRKIST, Jabalpur

E-mail of Corresponding Author: srit_vivek@yahoo.com

ABSTRACT

This review article presents the experimental and theoretical analysis of domestic refrigeration system by using wire-on-tube condenser with different spacing of wire, operating parameters like heat transfer rate, condenser pressure and condenser temperature, refrigerating effect is increased by using wire-on-tube condenser comparatively power consumption remain same as with air cooled condenser in a domestic refrigeration system. Therefore wire-on-tube condenser can replace the ordinary air cooled condenser in a domestic refrigeration system.

Keywords- Household refrigerator, wire-on-tube condenser, heat transfer.

INTRODUCTION

Condensers and evaporators are basically heat exchangers in which the refrigerant undergoes a phase change. Next to compressors, proper design and selection of condensers and evaporators is very important for satisfactory performance of any refrigeration system. Since both condensers and evaporators are essentially heat exchangers, they have many things in common as far as the design of these components is concerned. However, differences exist as far as the heat transfer phenomena are concerned. In condensers the refrigerant vapour condenses by rejecting heat to an external fluid, which acts as a heat sink. Normally, the external fluid does not undergo any phase change, except in some special cases such as in cascade condensers, where the external fluid (another refrigerant) evaporates. In evaporators, the liquid refrigerant evaporates by extracting heat from an external fluid (low temperature heat source). The external fluid may not undergo phase

change, for example if the system is used for sensibly cooling water, air or some other fluid.

Earlier different types of condenser slides air cooled condenser, water cooled condenser is been used in a domestic refrigeration system. Air cooled condenser is most popular condenser for a refrigerator. Many researches done in a past on the condenser, one of them wire-on-tube condenser where main tube is used in a spiral form with vertical wire (fines) with different spacing. Heat transfer rate increased by using this condenser.

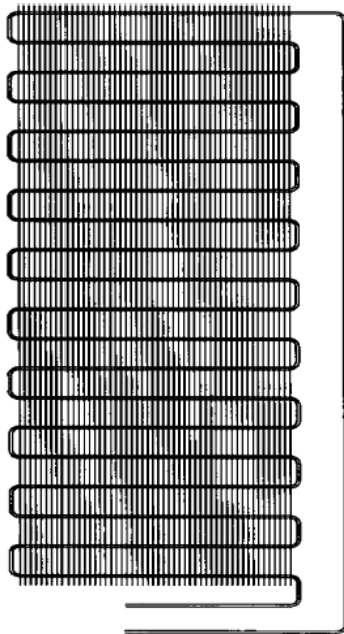

Fig. 1. Finned tube condenser used for experimental and theoretical study

Literature Review

1. **Bansal et al**-experimental analysis is done by using wire-on-tube condenser in a refrigerator with different operating parameters and compare these results with a simulation modeling finally they optimized the condenser performance.

2. **Looza et al**-evaluated the performance of wire-on-tube condenser with the help of basic operating parameters and compare with different fin design of condenser.

3. **Hoke et al**-they have performed with seven different spacing with wire-on-tube condenser for increasing the air heat transfer rate during operating this experiment new type of coil and heat exchanger is used.

4. **Tanda et al**-they investigated a Nusselt number and operating parameters for predicting the free convection heat transfer from a wire-on-tube condenser.

5. **Reeves et al**-the demonstrated the domestic refrigerator performance under of conditions , by using different instrumentations with different range of room temperature.

6. **Lee et al**- he developed heat transfer coefficient for wire-on-tube condenser using single layers.

Types of condensers:

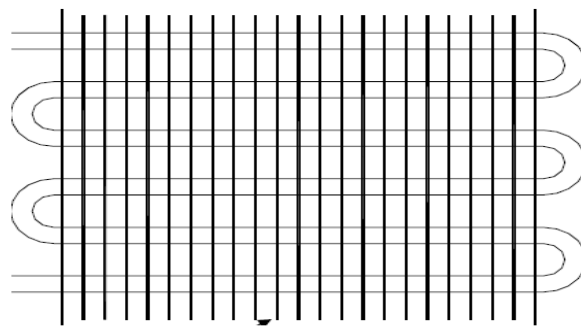
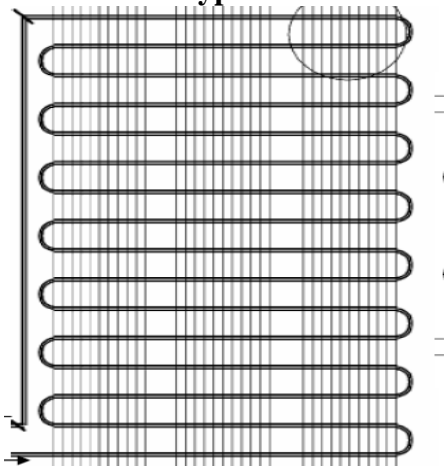

Fig. 2 Schematic of a wire-and-tube type & plate fin type condenser r used in small refrigeration systems

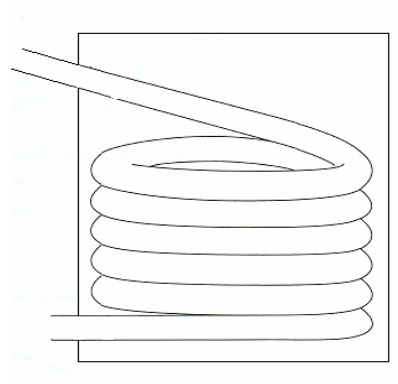
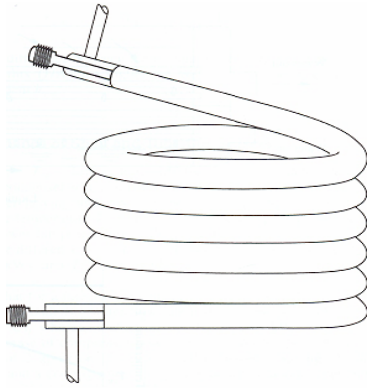

Fig. 3 Schematic of a Double pipe (tube-in-tube) type condenser & shell & coil type condenser used in small refrigeration systems.

Optimization of condenser-

In the past single coil air cooled condenser was used by the refrigerator companies, as the time progressed many changes is done by the researchers to enhance the performance of the condenser, different types of fins and coils with different shapes is now been used to increased the heat transfer rate by the air cooled condenser. Coils having different diameter also been used to increased then over all COP of the vapour compression refrigeration system.

CONCLUSION

Since many experimental and analytical study is done in recent passed on air cooled condenser, earlier R-12 refrigerant used in a refrigeration but because of its harmful effects in a Ozone Depletion Potential(ODP) has been replaced by R-134a using this refrigerant in a refrigerator performance is investigated with wire-on tube-condenser and found that heat transfer rate, maintenance cost increased and decreased respectively therefore wire-on-tube condenser can be replaced by the ordinary air cooled condenser used in a domestic refrigerator with out any change in a design of the component of the refrigerator.

REFERENCES

1. Numerical analysis and experimental investigation into the performance of a wire-

on-tube condenser Ahmadul Ameen et al International Journal of Refrigeration 29 (2006) 495–504.

2. B. Khastoo, Design and optimization of Iranian refrigerators, Research report in Amirkabir University, vol II, 2001.
3. S. Porkhial, Experimental and mathematical modeling of transient behavior of a domestic refrigerators (improving in refrigerator performance), Ph.D. Thesis, Amirkabir University, Mechanical Engineering Department, 2003.
4. B. Palm, Refrigeration systems with minimum charge of refrigerant, App. Therm. Eng. 27 (2007) 1693–1701.
5. T. Dutto, J.C. Blaise, T. Benedic, Performances of brazed plate heat exchanger set in heat pump, in: Proceedings of the 18th Int. Congr. Refrig., Montreal, Canada, 1991, pp. 1284–1288.
6. M.A. Kedzierski, Effect of the inclination on the performance of a compact brazed plate heat exchanger, Heat Transfer Eng. 18 (1997) 25–38.
7. Lesson 22 Condenser & Evaporator Version 1 ME, IIT Kharagpur 1.
8. A text book of refrigeration and air conditioning by R.S. KHURMI et al with a revised edition 2008.